

Foundation Specifications

for 4.5-/4.6-Meter Earth Station Antennas



1.0 INTRODUCTION

1.1 This document specifies typical foundation characteristics, designs, requirements and dimensional specifications for the Andrew 4.5-/4.6-Meter Earth Station Antennas.

2.0 FOUNDATION LOADING CHARACTERISTICS

2.1 Foundation loads are applied to the foundation pad as shown in Figure 1. Positive applied forces are in the direction of the X, Y, and Z coordinate axes.

2.2 Varying load conditions are dependent upon icing, incident angle of the wind and elevation/azimuth angles of the antenna. Foundation loading for various icing, elevation/azimuth and wind conditions are listed in Table 1. Foundation loading moment for various elevation/azimuth versus wind conditions are listed in Table 2.

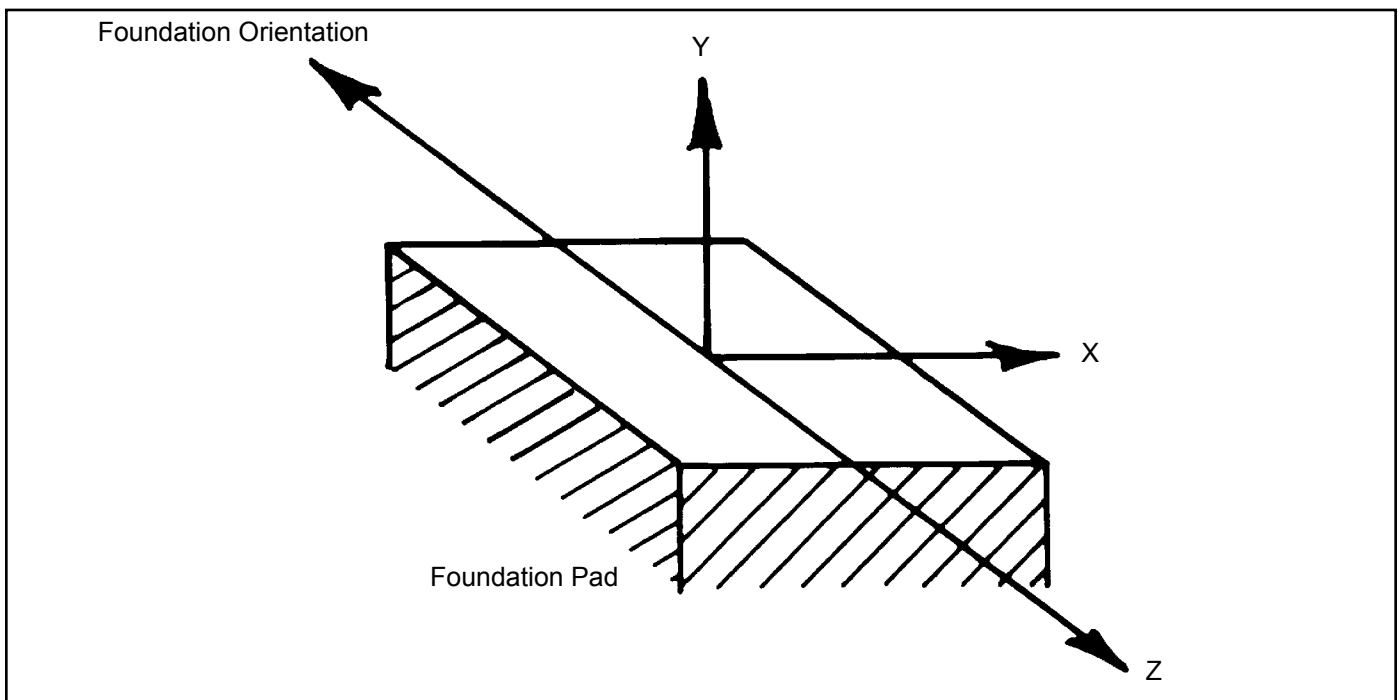

Figure 1



EL = 0°

FOUNDATION LOADING FORCES (lbs)

Wind Speed (mph)	Wind Angle (α)	AZ = 0°			AZ = +60°			AZ = -60°			AZ = 90°		
		x	y	z	x	y	z	x	y	z	x	y	z
125	15°	354	-1841	11220	-9543	-1833	5918	9896	-1847	5305	-11220	-1841	354
125	-15°	-354	-1841	11220	-9896	-1833	5305	9543	-1847	5918	-11220	-1841	-354
125	30°	530	-1841	11210	-9444	-1833	6065	9975	-1847	5147	-11210	-1841	530
125	-30°	-530	-1841	11210	-9975	-1833	5147	9444	-1847	6065	-11210	-1841	-530
125	45°	420	-1841	10870	-9203	-1833	5799	9624	-1847	5071	-10870	-1841	420
125	-45°	-420	-1841	10870	-9624	-1833	5071	9203	-1847	5799	-10870	-1841	-420
125	60°	-707	-1841	10030	-9039	-1833	4402	8332	-1847	5627	-10030	-1841	-707
125	-60°	707	-1841	10030	-8332	-1833	5627	9039	-1847	4402	-10030	-1841	707
125	120°	-2426	-1841	-2634	1069	-1833	-3418	-3494	-1847	783	2634	-1841	-2426
125	-120°	2426	-1841	-2634	3494	-1833	784	-1068	-1847	-3418	2634	-1841	2426
125	135°	-2281	-1841	-4263	2552	-1833	-4106	-4832	-1847	-156	4263	-1841	-2281
125	-135°	2281	-1841	-4263	4832	-1833	-156	-2551	-1847	-4106	4263	-1841	2281
125	150°	-1646	-1841	-5590	4018	-1833	-4220	-5664	-1847	-1369	5590	-1841	-1646
125	-150°	1646	-1841	-5590	5664	-1833	-1369	-4018	-1847	-4220	5590	-1841	1646

EL 30°

FOUNDATION LOADING FORCES (lbs)

Wind Speed (mph)	Wind Angle (α)	AZ = 0°			AZ = +60°			AZ = -60°			AZ = 90°		
		x	y	z	x	y	z	x	y	z	x	y	z
125	60°	-667	-6646	8804	-7957	-6638	3824	7291	-6653	4979	-8804	-6646	-667
125	-60°	667	-6647	8803	-7291	-6639	4979	7957	-6653	3824	-8803	-6647	667
125	135°	-1862	-845	-4350	2836	-837	-3788	-4698	-851	-562	4350	-845	-1862
125	-135°	1862	-845	-4350	4698	-837	-562	-2836	-821	-3788	4350	-845	1862

EL = 60°

FOUNDATION LOADING FORCES (lbs)

Wind Speed (mph)	Wind Angle (α)	AZ = 0°			AZ = +60°			AZ = -60°			AZ = 90°		
		x	y	z	x	y	z	x	y	z	x	y	z
125	±60	0	-10162	5627	-4873	-10154	2814	4873	-10168	2814	-5627	-10162	0
125	120°	-69	-762	-3417	2925	-753	-1768	-2993	-767	-1649	3417	-762	-69
125	-120°	69	-761	-3417	2993	-753	-1649	-2925	-767	-1768	3417	-761	69

EL = 90°

FOUNDATION LOADING FORCES (lbs)

Wind Speed (mph)	Wind Angle (α)	AZ = 0°			AZ = +60°			AZ = -60°			AZ = 90°		
		x	y	z	x	y	z	x	y	z	x	y	z
125	90° Side Wind	-1921	-949	0	-960	-941	-1664	-961	-956	1664	0	-949	1921
	Frontal Wind	0	-949	-1921	-1664	-941	961	1664	-956	961	-1921	-949	0
125	-90° Side Wind	1921	-949	0	961	-941	1664	960	-956	-1664	0	-949	-1921
	Frontal Wind	0	-949	1921	-1664	-941	961	1664	-956	961	1921	-949	0

Table 1

3.0 ANCHOR BOLT REQUIREMENTS

3.1 Typical anchor bolt installation configurations and dimensions are shown in Figure 2.

3.2 Andrew type 203666 Anchor Bolt Kit includes anchor bolts, alignment plates and required mounting hardware as shown.

4.0 FOUNDATION DESIGNS

4.1 The selected foundation for a particular site is dependent upon local conditions. Soil borings and foundation analysis should be performed by a qualified civil engineer.

EL = 0°		FOUNDATION LOADING MOMENT (in-lbs)											
Wind Speed (mph)	Wind Angle (α)	AZ = 0°			AZ = +60°			AZ = -60°			AZ = 90°		
		x	y	z	x	y	z	x	y	z	x	y	z
125	15°	985333	-48824	-32031	521078	-48829	837559	464633	-48838	-869208	32031	-48824	985333
125	-15°	985333	48824	33451	464299	48838	870256	521412	48829	-836512	-33451	48824	985333
125	30°	984407	-70569	-48407	534694	-70573	828390	449998	-70560	-876526	48407	-70569	984407
125	-30°	984406	70569	49834	449665	70560	877573	535028	70573	-827342	-49834	70569	984406
125	45°	952914	-94738	-38209	510056	-94753	806067	442959	-94748	-844014	38209	-94738	952914
125	-45°	952914	94738	39635	442625	94748	845062	510390	94748	-805019	-39635	94738	952914
125	60°	875109	-89366	66207	380659	-89357	790876	494458	-89367	-724343	-66207	-89366	875109
125	-60°	875109	89366	-64784	494125	89367	725391	380993	89357	-789829	64784	89366	875109
125	120°	-297894	232651	225420	-343669	232629	-145377	45783	232608	371040	-225420	232651	-297894
125	-120°	-297894	-232651	-223996	45542	-232649	-369993	-343335	-232653	146332	223996	-232651	-297894
125	135°	-448780	235374	211990	-407395	235320	-282740	-41220	235357	494973	-211990	235374	-448780
125	-135°	-448780	-235374	-210566	41554	-235357	-493925	-407061	-235344	283695	210566	-235374	-448780
125	150°	-571693	192460	153173	-417945	192441	-418528	-153546	192480	572037	-153173	192460	-571693
125	-150°	-571694	-192460	-151749	153880	-192480	-570989	-417620	-192441	419576	151749	-192460	-571694
EL = 30°		FOUNDATION LOADING MOMENT (in-lbs)											
Wind Speed (mph)	Wind Angle (α)	AZ = 0°			AZ = +60°			AZ = -60°			AZ = 90°		
		x	y	z	x	y	z	x	y	z	x	y	z
125	60°	684612	-76965	13558	330988	-76958	599555	-353588	-76876	-585703	-13558	-76965	684612
125	-60°	684464	76865	-12134	353254	76976	586750	331304	76858	-598477	12134	76865	684464
125	135°	-540579	155381	250334	-487154	155399	-342996	-53892	155381	593665	-250334	155381	-540579
125	-135°	-540593	-155381	248909	-54184	-155394	-592618	-485782	-155399	343134	-248909	-155381	-540593
EL = 60°		FOUNDATION LOADING MOMENT (in-lbs)											
Wind Speed (mph)	Wind Angle (α)	AZ = 0°			AZ = +60°			AZ = -60°			AZ = 90°		
		x	y	z	x	y	z	x	y	z	x	y	z
125	±60°	338700	0	712	169274	-8	293654	169607	8	-292607	-712	0	338721
125	120°	-500059	2889	11291	-259808	2889	-427418	-240624	2882	438930	-11291	2889	-500059
125	-120°	-499985	-2889	-9872	-240958	-2883	-437882	-258936	-2886	428429	9872	-2889	-499985
EL = 90°		FOUNDATION LOADING MOMENT (in-lbs)											
Wind Speed (mph)	Wind Angle (α)	AZ = 0°			AZ = +60°			AZ = -60°			AZ = 90°		
		x	y	z	x	y	z	x	y	z	x	y	z
125	90° Side Wind	2273	-240	317030	-272957	-226	154809	275358	-226	156939	317030	-240	-2273
	Frontal Wind	318653	0	770	159217	-9	281972	159598	9	-275292	770	0	-318653
125	-90° Side Wind	2304	240	-315610	275024	226	-150267	-272623	226	-159393	-315610	240	-2304
	Frontal Wind	318653	0	712	159217	-9	281964	159598	9	-275292	712	0	-318653

Table 2

4.2 A typical slab type foundation is shown in Figure 2. A copy of this design on a D-size (22" x 33") sheet is available from Andrew on request. Refer to drawing number 240001.

5.0 FOUNDATION ORIENTATION

5.1 Proper foundation orientation is required to obtain the

desired orbital arc coverage from a particular site location. The required azimuth and elevation angles of the antenna, relative to the mount must be determined to establish the appropriate foundation orientation. A specific foundation orientation requirement may be requested with the antenna as part of the installation package.

General Notes

1. Remove all burrs and sharp edges.
2. Dimensions apply before plating.
3. Interpret drawing per ANSI Y14.5M-1982.
4. Dimensions are shown in feet and inches. Dimensions in brackets [] are in millimeters.
5. A tolerance of $\pm 1/8$ " [3] applies to all anchor bolt layout dimensions.

6. Foundation Notes:

A) This foundation is a typical design only. Certification of it's suitability for a particular installation by a professional engineer is required prior to it's use for actual fabrication.

B) Contractor shall field verify all dimensions locating existing construction before fabrication of new construction begins.

C) Concrete and related work shall be mixed, placed and cured in accordance with "Building Code Requirements for Reinforced Concrete" ACI 318-89 (Rev. 88) and "Specifications for Structural Concrete" ACI 301-84 (Rev. 88) publication SP-15 (88).

D) Concrete for foundations shall develop a compressive strength of at least 3000 psi [211 kgf/cm²] in 28 days with a maximum slump of 3" [76] at time of placing.

E) Reinforcing bars shall conform to ASTM A 615 [S1] grade 60 deformed type $F_y = 60000$ psi [4219 kgf/cm²].

F) Unless otherwise noted, concrete cover of reinforcing bars shall conform to minimum requirements of ACI 318-89 (Rev. 88).

G) Fabrication of reinforcing steel shall be in accordance with "Manual of Standard Practice for Detailing Reinforcing Concrete Structures" ACI 315-80 (Rev. 86).

H) Provide 3/4" x 45° [19 x 45°] chamfer on all exposed concrete edges.

J) Foundations have been designed to rest on undisturbed soil (per EIA-411-A and RS-222-D) with a minimum allowable net vertical bearing capacity of 2000 psf [9770 kgf/m²]. If undesirable soil conditions are encountered, the engineer shall be notified.

K) Backfills shall be suitable excavated material or other suitable material compacted in 6" lifts to 90% of maximum density as determined by ASTM D1557.

L) If this foundation is to be located in an area where annual frost penetration depth exceeds 15" [381], the local building code specifying a minimum required foundation depth should be consulted.

7. Grounding Electrode System Notes:

The grounding system shown represents the minimum requirements to achieve satisfactory grounding. Actual site conditions and soil resistivity levels will determine final grounding system design to comply with the following:

A) All ground ring, ground rod and antenna structure connections to be EIRCO® products, Inc. Calweld® exothermic type welded electrical connections or equivalent.

B) Ground rods shall be driven to a depth below permanent moisture level (minimum depth shown) as dictated by geographical location.

C) The antenna structure shall be connected to a grounding electrode system consisting of a number of interconnected ground rods. The system shall meet the requirements of the Underwriters' Laboratories Publication No. ,UL96A for Lightning protection.

D) The grounding electrode system to earth resistance shall not exceed 10 Ohms, measured with a Biddle 3 terminal device or equivalent. The grounded conductor (neutral) supplied to all ac equipment on the antenna structure should be disconnected before taking measurement.

E) Actual site conditions may require longer ground rods, additional ground rods and/or land fill additives to reduce soil resistivity levels.

F) Avoid sharp bends when routing grounding wire. Grounding wires to antenna structure to be run as short and straight as possible.

G) Final grade directly above grounding electrode system to be water permeable.

8. Power/IFL Conduit Notes:

A) Electrical power - Drawing depicts suggested location for electrical power conduit to antenna. Size, type and depth to bury conduit to be determined by customer in compliance with local codes. Direction to route conduit to be determined by the relative location of communications building/shelter. Power conduit to extend 6" (minimum) above surface of foundation slab. Open ends of conduit to be sealed to prevent moisture and foreign particle contamination.

Customer to provide main load center assembly and over-current protection devices for electrical equipment. Mounting location of load center to be determined by customer in accordance with local codes.

B) For routing IFL cables, 4" size conduit recommended. Type and depth to bury conduit to be determined by customer, in compliance with local codes. Location of conduit on foundation and direction to route conduit to be determined by location of communications building/shelter. Conduit to extend 36" (minimum) above surface of foundation slab. All bends to be large radius, maximum of two bends per run. Open ends of conduit to be sealed to prevent moisture and/or foreign particle contamination.

6.0 ANTENNA GEOMETRY

6.1 Figure 3 illustrates basic dimensional characteristics and azimuth adjustment range capabilities of the 4.5-meter motorizable antenna. Figure 4 illustrates the corresponding characteristics and capabilities of the 4.6-meter antenna.

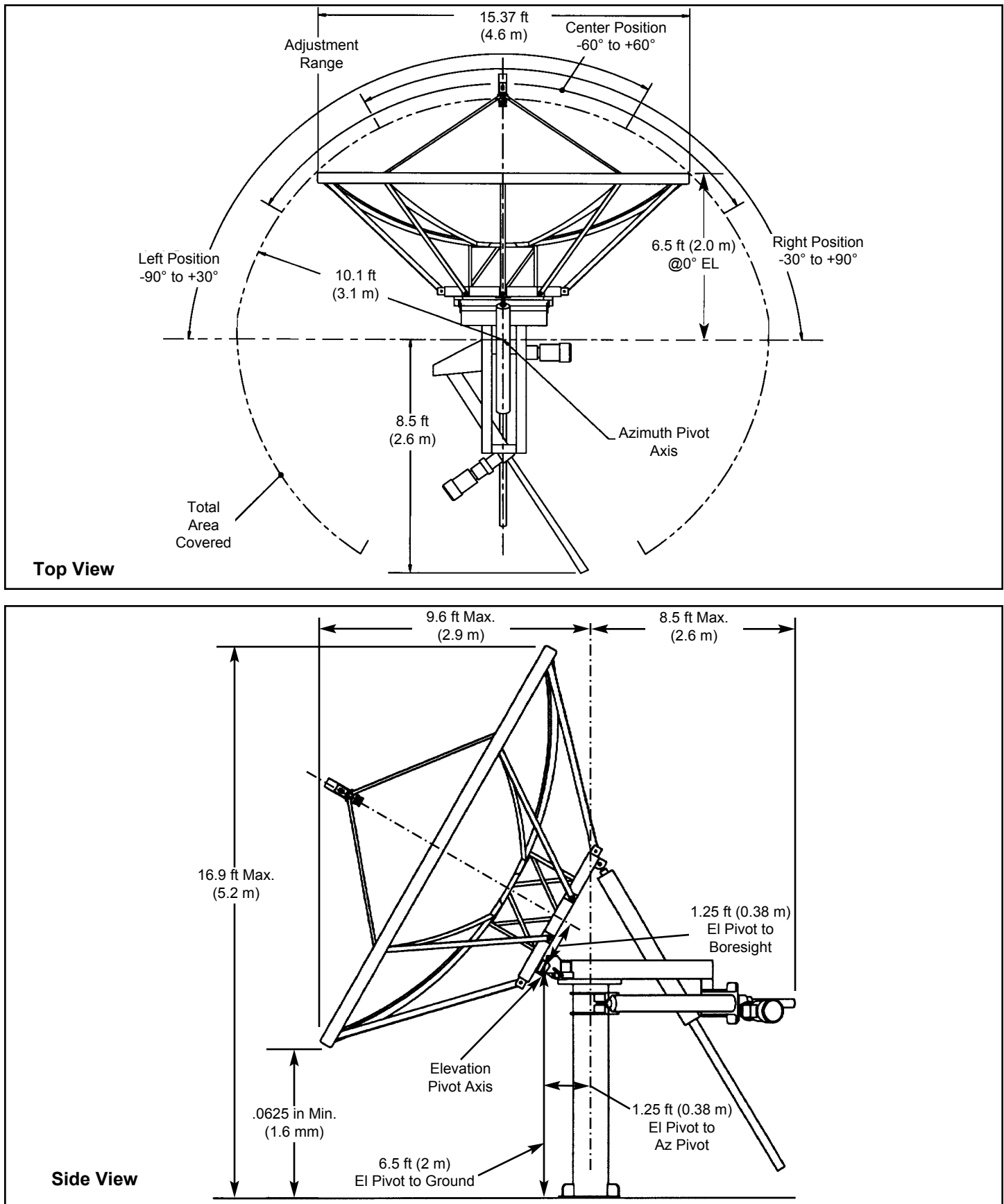

Figure 3 - 4.5-Meter Earth Station Antenna With Motorizable Mount

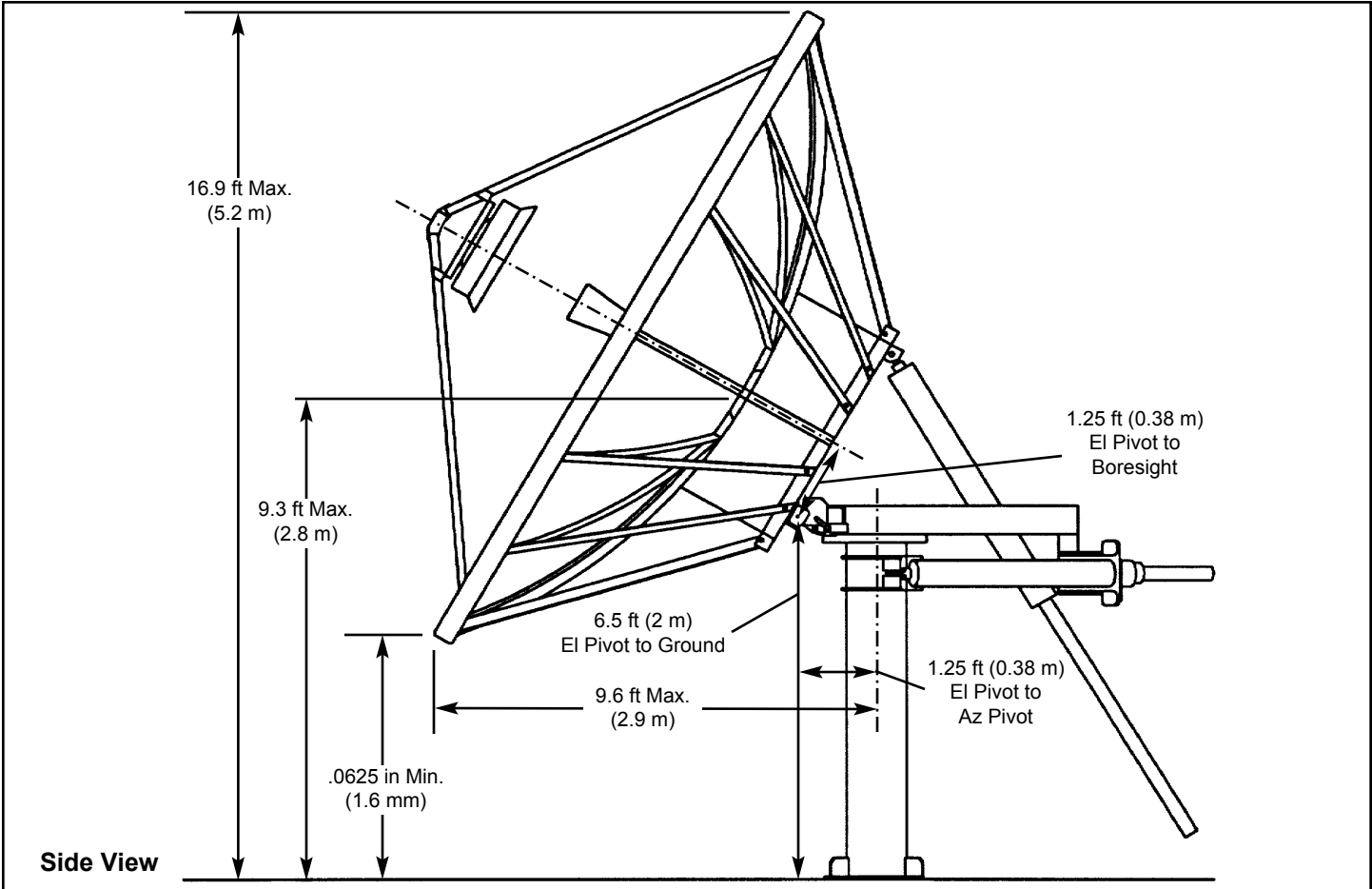
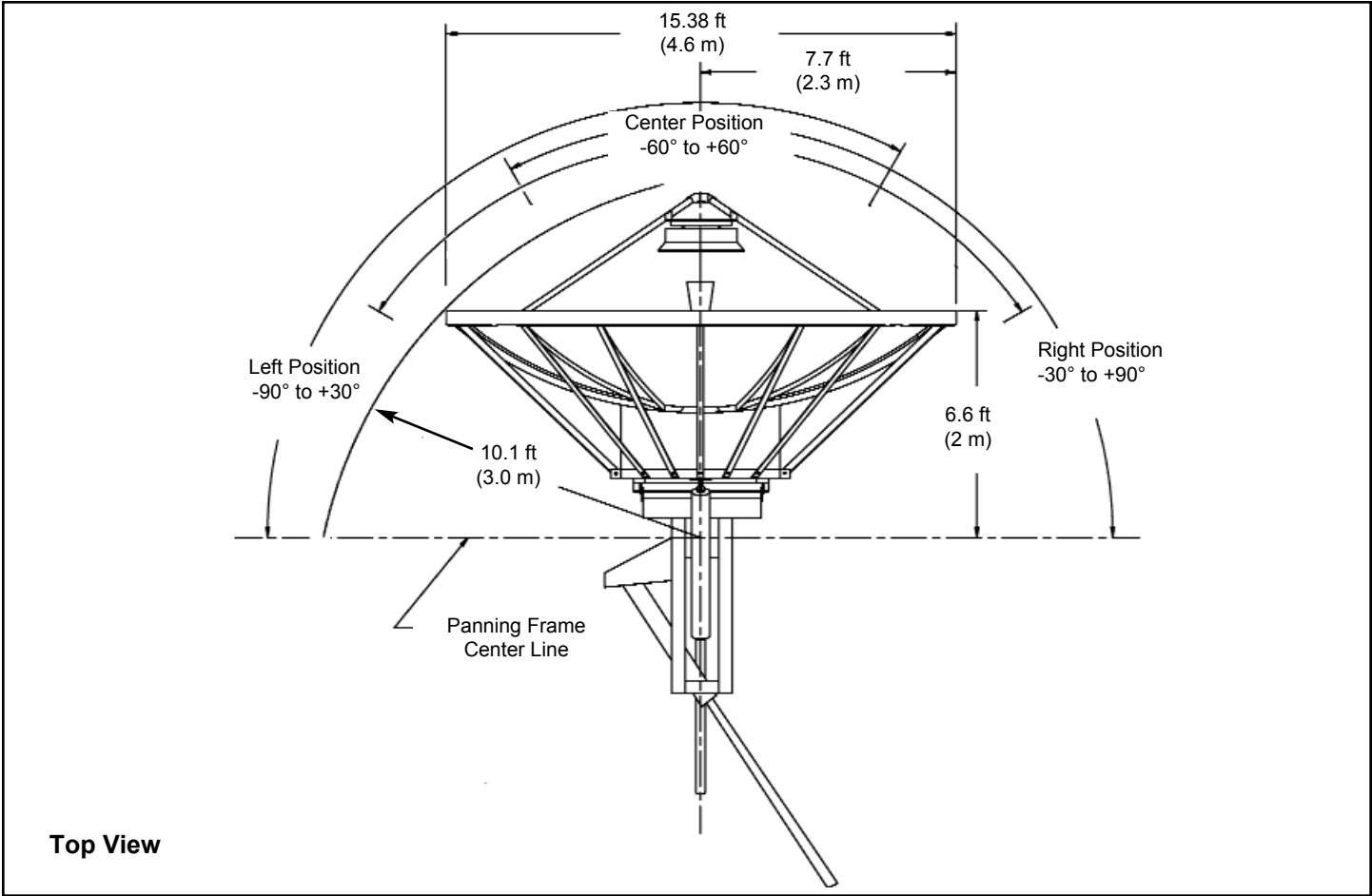

Figure 4 - 4.6-Meter Earth Station Antenna With Motorizable Mount

Figure 5 illustrates varying dimensions from ground reference of selected antenna points as the elevation angle fluctuates from 0° to 90°.

